



— USER MANUAL —



All rights reserved. No part of this publication may be reproduced, stored in computer systems or transmitted in any form or by any electronic or mechanical means, photocopies, registration or any other means, without the prior written consent of ELETTRROLASER S.r.l.. The information herein refers exclusively to this DADO model.

ELETTRROLASER S.r.l. cannot be held liable if this information is used for other LASER welding machines.

ELETTRROLASER S.r.l. and affiliates cannot be held liable to the purchaser or third parties for any damage, loss, costs or expenses incurred due to: accidents, improper or abusive use of this product, modifications, unauthorised repairs or alterations carried out on this product, or failure to strictly comply with the operating and maintenance instructions provided by ELETTRROLASER S.r.l..

ELETTRROLASER S.r.l. cannot be held liable for any damage or problems caused by consumables being used other than those indicated as original products and/or approved by ELETTRROLASER S.r.l..

The manufacturer guarantees no defects in new machines, considering current technological progress, for two years from the delivery date indicated in the transport documents. Notwithstanding the period of validity indicated in the previous point, the warranty will also cover parts of the machine not directly manufactured by ELETTRROLASER S.r.l., excluding the optical fibre, lamps, fuses and all consumables. The manufacturer must provide a warranty and proceed at their discretion to perform repairs or replace faulty parts based on technical requirements.

If the manufacturer acknowledges the warranty rights, all costs related with the relative interventions must be charged to the manufacturer.

Parts with manufacturing and/or processing defects must be replaced, as well as all consequently damaged parts. Replaced parts will become the property of ELETTRROLASER S.r.l.. If any faulty part is replaced, this will not result in the warranty period being extended, neither for the replaced parts nor for the machine as a whole. ALL INTERVENTIONS ARE CARRIED OUT IN THE ELETTRROLASER S.r.l. PREMISES. FOR THIS REASON, WE RECOMMEND CUSTOMERS TO KEEP THE ORIGINAL PACKAGING JUST IN CASE THE MACHINE MUST BE MOVED.

In addition to a specific written request, an ELETTRROLASER S.r.l. technician can be called to visit the customer's premises to provide assistance for the machine and install and activate the parts that must be replaced. In this case, regardless of whether the machine is under warranty or not, the transfer costs will be charged to the customer. The warranty will no longer be valid if the noted error is due to the following:

- The buyer did not inform the manufacturer of the defects within eight days from the date of delivery, in writing or by commissioning the relative intervention;
- The machine or its parts were used improperly and in a different way from the intended use;
- Repairs were first carried out on the equipment by third parties, unrelated to ELETTRROLASER S.r.l. or not specifically authorised by ELETTRROLASER S.r.l..
- The components were installed on the machine, the use of which was not authorised by ELETTRROLASER S.r.l., or the machine and the spare parts themselves were subjected to modifications that were not authorised by ELETTRROLASER S.r.l..
- The instructions in this user manual regarding machine use and maintenance were not complied with.
- Signs indicate that the closing panels were opened and the warranty label was violated.
- Defects, faults and damage caused by normal wear or natural events are also excluded from the warranty.
- Periodic services, calibration, scheduled and extraordinary maintenance are not covered by the warranty.

If the machine is sent to the ELETTRROLASER S.r.l. facilities for scheduled/extraordinary maintenance, ELETTRROLASER S.r.l. will reimburse the customer for all costs related to the pure transport costs, only if the machine is under warranty.

However, ELETTRROLASER S.r.l. is not obliged to pay additional costs, such as insurance coverage, etc., to the extent that ELETTRROLASER S.r.l. cannot be held liable for machine damage and/or loss while it is being transported.

It is recommended to use only the original packaging. Any All Risk insurance costs will be charged to the customer.

Notwithstanding the validity of the purchaser's warranty rights described in the above mentioned terms and

CONTRACTUAL GUARANTEE

conditions, the purchaser's right to request the termination of the contract and/or the replacement of the machine is specifically excluded.

If omissions and/or negligence by the user should generate the need for one of our technicians to intervene, the relative expenses will be charged to the customer by ELETTRROLASER S.r.l..

If a fault is noted during the warranty period, ELETTRROLASER S.r.l. will see to its elimination free of charge, in full compliance with the "Warranty conditions".

Acknowledgement of the warranty does not grant the right to claim any kind of compensation.

ELETTRROLASER S.r.l.

Stamp and signature for acceptance of the
"warranty conditions"

Dado [®]

TABLE OF CONTENTS

	Contractual Guarantee	2
A	SAFETY	6
	Absorption of Laser Radiation	8
	Classification and Hazards	9
	Radiation Viewing Conditions	9
	Risks for Eyes and Skin	10
	General Safety Requirements	10
	Collateral Risks	10
	Safety Systems	11
	Safety Labels	13
B	HOW IT IS MADE	16
	Precautions for use	18
	Technical Specifications	19
	How it works	19
C	INSTALLATION	20
	Contents of the Box	22
	Unpacking the Machine	23
	DADO Parts Diagram	24
	Assembling the Accessories	25
	Adding Coolant	25
	Positioning of the Controls	26
	First Start-up	29
D	WELDING WITH DADO	30
E	TROUBLESHOOTING, ANOMALIES AND MAINTENANCE	34
	Error Messages	36
	Anomalies	37
	Replacing the AR/AR Protection Glass	38
	Aligning the Aiming Cross	38
	Changing the Coolant	39
	Technical Support	40
	Contacts	40
	EEC Conformity and CE Marking	41
F	GENERAL SAFETY REQUIREMENTS DURING WELDING	42
	Protection Systems	44
	Special Requirements	45
	Positioning of the Controls and Labelling	45
	Requirements of Use	45
	Personal Protective Equipment (PPE)	45
	Residual Risks	46

SAFETY

A

Topics related to individual safety are discussed in this chapter.

The tests carried out demonstrate the safety and reliability of the laser when it is used properly. However, the operator must be aware of the precautionary regulations aimed at avoiding possible harm to people or damage to the equipment itself.



CAUTION: incorrect application of the safety regulations during the practical use of the welding machine described in this manual can lead the user to harmful exposure to laser radiation. Follow the procedures carefully. ELETTROLASER S.r.l. declines all liability for damage caused by negligence in applying the indicated safety regulations.

LASER RADIATION

Laser radiation is an electromagnetic emission with micrometric wavelength that is located in the far infrared (CO₂ laser), in the near infrared (Nd-YAG, Nd-YVO₄ laser), in the visible (He:Ne or Argon laser), or ultraviolet (excimer laser) ranges.

It is considered Non-ionising radiation. In the DADO laser, the emission of a crystal bar is stimulated by the “optical pumping” generated by a power laser lamp. The continuous bouncing of photons between a front and rear mirror generates a positive reaction and their number increases moment by moment, until the necessary concentration to produce a beam is reached, which comes out of the front semi-reflective mirror. The reaction (which we can imagine as an “invisible light beam”) is then collimated and focused with lenses at a point, in which the intensity becomes so high that it can react with different materials causing an alteration due to the thermal effect.

As for the above, DADO laser radiation is invisible however, being close to the visibility threshold causes the eye to receive it almost entirely with no pupillary reflex. If we add that it is generally very intense, it can be extremely harmful or lethal for the vision.

Certain precautions must be followed so as to avoid permanent personal injury.

All people who may be exposed to harmful laser radiation levels must know when the laser is active, and if so, they must wear protective eyewear.

Due to the high power, the laser integrated in the machine causes laser light to be reflected by flat surfaces. Reflected light is potentially dangerous to the eyes and skin. The electromagnetic emission with micrometric wavelength is located in the far infrared and is therefore invisible, so it is not clear where the reflected beams are directed.

ABSORPTION OF LASER RADIATION

Human tissue absorbs the electromagnetic radiation differently, depending on the wavelength of the radiation itself. Both the eye and the skin have their own “predisposition” to accept certain wavelengths and are more refractory to absorbing others. In the specific case of the eye, the cornea and the crystalline lens let all the wavelengths ranging from 400 to 1400 nm, namely the range between visible light up to the infrared IRA, pass and reach up to the retina, even with different attenuations. Therefore, it must be immediately noted that the Nd:YAG laser radiation (wavelength 1064nm) **involves direct exposure of the retina** since it falls within this range. As for the skin, the “biological window” is different in absorption percentages but is not dissimilar in wavelengths. However, as can be easily foreseen, the maximum exposure values allowed for skin compared to those that can be tolerated by the eye are very different.

As for the damage mechanism that the absorbed radiation can cause, this also depends on the wavelength. Short wavelengths (ultraviolet UV-C 180-280nm, UV-B 180-280nm, UV-A 315-400nm) generally generate photochemical effects: cataract or opacification of the crystalline lens,

melanic colouring or reddening of the skin. Greater wavelengths (infrared: IR-a 780-1400nm IR-c 3000-10 E6nm) generally generate thermal effects: detachment and photocoagulation of the retina, burning of the skin. The degree of damage caused obviously depends on the **amount of radiation absorbed** and the **instantaneous power** of the radiation source.

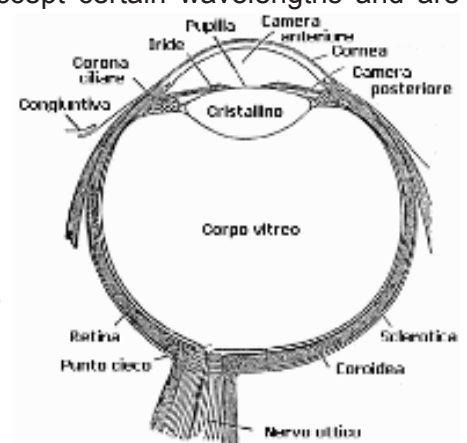

Figure 1 - Eyeball

CAUTION: direct viewing of a laser beam can **cause irreversible damage to the eye.**

CAUTION: **it is essential to protect yourself from the beams of reflected light** because they can be sufficiently intense to cause permanent damage to the eyes or skin.

CAUTION: The laser in question falls under **class IV**. Class IV lasers generate risks not only by direct or reflected radiation but also by **diffused radiation**. These laser sources can pose a significant hazard for the skin and the risk of fire of inflammable materials.

CLASSIFICATION AND HAZARDS

Legislation has established various classes of laser hazards based on their ability to harm people, from the class I laser (intrinsically safe in all conditions) to the class IV laser, which is dangerous under different conditions.

Class III lasers bear the “WARNING” label and should not damage the eye for temporary viewing (thanks to the self-defence eyelid reflex from intense visible radiation), but which can pose a severe hazard if observed through a microscope or magnifying glass. Other lasers belonging to the same class but bearing the “DANGER” label can exceed the maximum exposure level permitted, already over 0.25 seconds.

Class IV lasers generate risks not only by direct or reflected radiation but also by diffused radiation. These laser sources can pose a significant hazard for the skin and the risk of fire of inflammable materials. For these reasons, the user must establish all radiation containment measures to ensure that it is terminated at the end of its useful process. Furthermore, the operator must be informed of the risks deriving from exposure to laser radiation and must be equipped with the appropriate PPE (personal protective equipment), which consists of certified protective goggles against laser radiation.

RADIATION VIEWING CONDITIONS

The laser output by the resonator is to be considered a highly collimated and intense monochromatic light source. Thanks to these characteristics it can be considered a very bright “point source”. This means that its “image” is then focalised on the Retina in a very small spot with dangerously high power density! If, on the other hand, the beam becomes divergent and scatters to a non-reflecting screen, there then will be an “extended viewing” of the image, with a significantly less dangerous power density. Therefore, different types of radiation viewing can be distinguished in relation to how the radiation itself can be accessed and consequently, different degrees of risk.

- ***Direct viewing of the laser beam***
This type of viewing is the most dangerous and can occur at the outlet of the laser aperture, after removing the lenses. It must be avoided in every way! No protective goggles can be considered a valid means against direct viewing of the beam.
- ***Direct viewing of the beam after mirror reflection***
This can occur by directing the beam on a reflective surface. Viewing a mirror reflected beam on a flat surface is extremely dangerous, just like direct viewing.
- ***Direct viewing of the beam at the output of an Optical fibre***
Connecting the Optical fibre from the resonator. Viewing the beam is dangerous up to a significant distance. Filters and goggles cannot guarantee safety.
- ***Viewing the beam directly after focusing***
This occurs if the laser beam is not extinguished on a suitable absorber at the end of its useful path. Viewing the beam is dangerous up to a significant distance. Filters and protective goggles can guarantee safety for brief exposure, as long as they are the right size and certified.
- ***Scattered viewing of the Laser beam after focusing***
This is the most common viewing condition for equipment in an operative setting. Viewing the beam is not dangerous if not at a short distance, but adequate filters and Goggles can guarantee safety, even for long exposure.

**The Nominal Ocular Hazard Distance (NOHD) for the DADO laser is less than 15 m, for direct or mirror reflected radiation, and less than 0.5 m for diffused radiation!
Only suitable goggles with Optical Density (OD) greater than 4 can temporarily protect the eyes from the accidental vision of harmful laser radiation!**

FOR EYES AND SKIN

If subjected to intense laser radiation, even of brief duration, or to less intense but long lasting radiation, both the cornea and the retina can burn and be irreparably damaged. This consequence is quite realistic in the case of direct viewing a class IV Laser beam.

If subjected to direct focalised radiation, even the skin can burn. Furthermore, it must be considered that collateral radiation can coexist with the main radiation in the ultraviolet: long exposure can cause skin carcinoma.

GENERAL SAFETY REQUIREMENTS

In order not to reduce the safety level of the equipment, the User must adopt conforming behaviour and in the best possible safe conditions. Therefore, the need arises to develop a Standard Operating Procedure (SOP) in relation to the manoeuvres to be carried out for commissioning and decommissioning the equipment. This procedure, which is illustrated near the installation, must be used as a reference for the Operator and will be written in their own language.

Personnel training will be essential, which must be aimed at:

- Familiarising with the operating procedures of the system.
- Knowledge of the biological effects of radiation on Eyes and Skin
- Understanding the need for Personal Protective Equipment (PPE)

COLLATERAL RISKS AND SAFETY SYSTEMS

An additional risk may be posed by a fire outbreak from processing materials other than those for which the equipment is intended.

CAUTION: If the intended use of the source is changed, for example for material process applications, collateral risks may arise due to fumes and vapours being generated which may be irritating or toxic if not removed and filtered properly before releasing them back into the environment.

NOTE: It is advisable not to change the intended use without having previously contacted the Manufacturer.

CAUTION: Since there is a risk of fire when processing flammable materials, it is essential to follow the instructions provided by the manufacturer when commissioning the machine.

CAUTION: Do not subject material to the laser radiation other than what the equipment was built for.

Electricity is certainly the most serious collateral risk associated with a laser device, which may also be fatal. This can arise when the warnings and procedures imposed by the equipment manufacturer are not observed. Unauthorised and inexperienced personnel must never carry out any type of intervention on the electrical part. The safety devices must never be removed and their efficiency must be checked regularly.

CAUTION: Do not intervene on the electrical part unless you are an expert. **Do not remove the protective devices.**

CAUTION: When processing **flammable materials**, it is essential to follow the instructions provided by the manufacturer when commissioning the machine.

COLLATERAL RISKS AND SAFETY SYSTEMS

If, for example, during the processing in the intended use of the Laser source, the material is subjected to alterations and produces irritating and/or toxic fumes or vapours, these must be removed and filtered before releasing them back into the environment.

An additional risk may be posed by a fire outbreak from processing materials other than those for which the equipment is intended.

This LASER welding machine is equipped with several safety systems to prevent the LASER radiation from not being checked by the machine in any way.

NOTE: Do not subject material to the laser radiation other than what the equipment was built for.

NOTE: Since there is a risk of fire when processing flammable materials, such as plastics, it is essential to follow the instructions provided by the manufacturer when commissioning the machine.

SAFETY SYSTEMS

Below is a list of such systems and the description of how they work:

1. RESONATOR SHUTTER

Description	This device consists of a small piston controlled by an electromagnet and is found inside the LASER resonator. The shutter intervenes and interrupts the LASER path inside the resonator when the welding machine is in STAND-BY mode
Purpose	The purpose of this device is to prevent unwanted LASER radiation from being generated
Operation	When the electricity is connected, the block is active. Unlock by keeping the knob inside the welding chamber pressed and an acoustic signal will indicate its release. The lock will only work if there are errors, if the knob is pressed to set the machine in stand-by or when the power supply is disconnected.

2. INFRARED MICROSCOPE FILTER

Description	This filter is an optical glass that is opaque to 1,064 nm LASER radiation. To our eyes it appears as light grey and perfectly transparent. It is found inside the optical tube.
Purpose	The purpose of this filter is to protect the operator's eyes from leaks of the optical path of the LASER radiation microscope, even if absolutely unlikely in this area.
Operation	Being opaque at the 1,064 nm wavelength, it prevents the LASER radiation being used in any direction from passing.

3. INFRARED MICROSCOPE FILTER

Description	<p>This device consists of a liquid crystal filter (LCD) which darkens completely when subjected to a precise voltage. It is found between the 45° mirror and the focus lens of the microscope.</p> <p>The shutter intervenes by interrupting the operator's visual path through the microscope, when the LASER pulse causes the piece being welded to melt (figure 2 ref. A).</p>
Purpose	<p>The purposes of this device are:</p> <ul style="list-style-type: none"> • to prevent the glare of the operator caused by the flash of light with visible radiation emanating from the welding bath. <p>Later we will see that this protection is the second of three devices that prevent the anomalous path of the LASER radiation towards the eyes of the operator.</p>
Operation	<p>The position of the OPEN SHUTTER is the normal condition of this device both with the machine in STAND-BY mode (resonator shutter ON) and in START mode (resonator shutter OFF).</p> <p>This allows the microscope to be used at any time.</p> <p>After setting the machine in START mode, the operating logic of the shutter is as follows:</p> <ul style="list-style-type: none"> • Pressing on the shot pedal • The microprocessor detects the closure of the pedal contact and commands the closure of the shutter. • The microprocessor enables the LASER lamp to be switched on. • The shutter remains in the ON condition for a period of time related to the length of time the LASER lamp is on, plus reasonable time to allow the melting bath to cool down and therefore lose its brightness. • Return to the idle position with detection of the complete opening of the shutter.



Figure 2 - Microscope shutter filter

SAFETY LABELS

The welding system has seals in some points. For no reason whatsoever must the seals be broken or removed. The sealed parts, in fact, can only and exclusively be opened by ELETTRROLASER S.r.l..

Labels and plates are applied to the equipment in accordance with European safety regulations. They must not be removed or damaged. For any replacements, contact ELETTRROLASER S.r.l..

NOTE: Breaking or removing seals affixed to the laser system by the manufacturer **immediately renders the warranty on the entire welding system null and void.**

WARNING LABELS



Figure 3 - Laser Warning

This label indicates the presence of the laser without specifying the class it belongs to. It is found on the back of the machine, near the slide of the resonator where the laser beam is emitted from.



Figure 4 - Laser class information

This label indicates the presence of the laser, specifying the class it belongs to.



Figure 5- Laser opening information

This label indicates the area where the laser exits the machine.



Figure 6- Laser exposure information

This label indicates the presence of the laser, specifying the class it belongs to and the power of the machine being used.

Carefully read the warnings in this section before using the laser welding machine. Make sure that all warnings and instructions displayed on the machine are observed. The following warnings are indicated to ensure our products are used safely and to prevent damage or injury to operators or other persons. Make sure that you have taken all the precautions indicated in the manual; all precautions are important for personal and work safety.

THE LASER WELDING MACHINE COULD BE DANGEROUS

Protect yourself and others from potential serious injury or death. Always wear protective eyewear. Keep children away from the machine. Persons with pacemakers must stay away from the machine, unless they have specific medical permission. Operators may be exposed to certain risks when using lasers. Welding is safe if the necessary precautions are adopted. Risks related to welding are limited to handling manufactured products. The process itself is extremely safe. In any case, it is important to delegate machine use only to authorised personnel. The installation, maintenance and repairs of the machine must be delegated to

ELETTROLASER S.r.l. personnel or to its authorised technicians.

ELECTRICAL DISCHARGES CAN BE FATAL

Contact with live electrical parts can have fatal consequences or cause severe burns.

Incorrect installation or earthing the machine can be dangerous.

- Do not touch live parts. Remove the power cable from the power socket before installing or performing maintenance on the machine.
- Install and earth the machine properly, in accordance with the user manual and in full compliance with local regulations and standards.
- Switch the machine off after use.
- Do not use cables that are weak or damaged, with an insufficient section or poorly connected.
- Make sure that the cables are positioned away from sources of heat.
- Use the device only if it is in perfect condition. Make sure that the damaged parts are immediately repaired or replaced.
- Make sure that all the cover panels remain fixed and in place.

SWITCH THE MACHINE OFF IMMEDIATELY IN CASE OF MALFUNCTIONING

If smoke or unusual odours are emitted from the equipment, immediately unplug the power cable, while taking care to prevent burns or damage. Continuous use of the laser welding machine in such conditions can cause serious injury and/or damage. The device must only be examined by ELETTROLASER S.r.l. technical personnel or by their authorised technicians.

DO NOT ATTEMPT TO DISMANTLE THE EQUIPMENT

The internal components of the device can cause injury. If the product malfunctions, it must only be repaired by skilled ELETTROLASER S.r.l. personnel.

DO NOT USE IN THE PRESENCE OF FLAMMABLE GAS

Prevent the risk of explosion or fire by not using the equipment in environments saturated with flammable gas with minimal ventilation. Always keep a fire extinguisher nearby.

FUMES AND GAS CAN BE HAZARDOUS FOR HEALTH

The welding processes produce fumes and gas. Inhaling these can be dangerous to human health.

- Keep your head away from the fumes. Do not inhale the fumes.
- Do not cover any part of the machine.
- Carefully read the instructions for the various types of materials that can be laser welded.
- It is preferable to use a large room specifically designed for the equipment to be used. If the room is small, make sure it is well ventilated.
- Do not weld nearby degreasing, cleaning or steaming areas. The heat can react with the vapours,

thereby producing very toxic and irritating gas.

- Make sure that the materials used do not contain impurities that could produce fumes or gas during laser welding.

WELDING CAN GENERATE A FIRE OR EXPLOSION

Sparks and overheating can be generated by the welding materials during processing and cause a fire and/or burns. Accidental contact of the overheated parts with the gas cylinder could cause an explosion.

- Do not laser weld where the sparks could come into contact with flammable material.
- Remove all flammable objects found near the LASER welding machine. If this is not possible, cover them correctly with flame retardant material.
- It is important to be aware of the risks of fire: always keep a fire extinguisher nearby.
- Actively supervise the machine during operation.

LASER RADIATION CAN CAUSE INJURIES TO THE RETINA AND BURNS TO THE SKIN

Make sure that the protection fringes in the welding chamber are always present. Uncontrolled reflections of the LASER beam can cause burns or, in the worst case, irreversible damage to the retina. Never weld on reflective objects. Keep children away when using the equipment.

Reproduction, transmission, transcription, insertion into a data recovery system, translation into any language, in any form and by any means, is strictly prohibited without prior authorisation.

ELETTROLASER S.r.l. reserves the right to modify the hardware and software information in this manual

at any time without notice. ELETTROLASER S.r.l. declines all liability for any kind of damage caused by using this product. Despite our attempt to make sure that this documentation is as complete and accurate as possible, we kindly ask you to immediately inform ELETTROLASER S.r.l. of any errors or omissions.

WASTE SEPARATION

This symbol indicates that this product must be disposed of in special waste containers.

The following instructions are intended exclusively for cases where the equipment is used in European countries:

- This product must be disposed of in special waste containers. Do not dispose of with household waste.
- For further information, please contact the local authorities responsible for waste disposal.

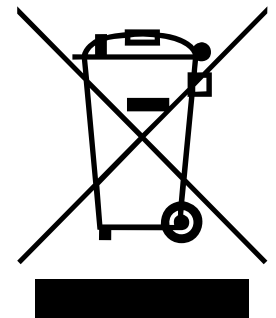

HOW IT IS MADE

B

This manual was produced to start your experience with the DADO welding machine in the best way.

It is essential to read the contents of this manual just like it is essential that your skills are enhanced together with DADO.

The basics of DADO are explained in the first chapters, how to install the product and how to set it correctly by starting your welding experience in the best way.

ELETTROLASER S.r.l. is pleased to welcome you to the DADO world.

Have fun.

CAUTION: incorrect application of practical use and/or the procedures described in this manual, can lead the user to harmful exposure to laser radiation. Follow the procedures carefully.

NOTE: it is forbidden to change the intended use for which the system has been designed and implemented. ELETTROLASER S.r.l. declines all liability related to improper use of the equipment it produces.

PRECAUTIONS FOR USE

LASER SAFETY MANAGER (ASL)

- It is the employer's responsibility to appoint a laser safety manager, who must be skilled in using LASER equipment and on LASER safety, in order to assess the potential risks associated with machine use.
- The LASER safety manager (ASL) must:
 - Have the required knowledge to carry out their task accordingly. There is no law that specifies how this knowledge should be acquired.
 - Be responsible for the equipment activation key.
 - Adequately train operators on the safety and management aspects of the work process.
 - Establish a controlled LASER zone (ZLC) where the equipment can be used safely (see the relative chapter).
 - Isolate the area where the equipment is used with panels and posters that prohibit access to unauthorised personnel.

BEFORE EVERY USE

The following instructions must be complied with for the equipment to be used correctly:

- Do not insert foreign objects into the grooves/holes of the equipment.
- Pay utmost attention not to spill liquids on the equipment.
- Always switch off the device from the main switch.
- Perform maintenance as described in the relative chapter, at regular intervals.
- or If the focus lens is dirty, wipe it with a dry or slightly damp cloth. If it is very dirty, use a neutral detergent, such as alcohol. Never use thinners, benzene, etc., as they may discolour or alter the plastic components. If the lens is damaged, contact technical support.
- Use the buttons and the touch screen display carefully, with your fingers. Press the buttons one at a time; if several buttons are pressed simultaneously, the device may not respond or it could be damaged.

TRANSPORT PRECAUTIONS

Follow the precautions below when transporting the laser welding machine so as to prevent potential risks.

- Pack the laser welding machine before transporting it.
- The operator must wear personal protective equipment, including a helmet, accident prevention shoes and gloves. (Leather gloves are recommended).
- When transporting the equipment, use a forklift, a crane, a belt, etc. with a load capacity of at least 500 kg.
- Remove all equipment accessories while it is being transported.
- Avoid hitting and dropping the equipment while it is being transported so as to avoid damaging the electrical parts and internal optical components.

INTENDED USE OF THE WELDING MACHINE

The family of laser welding machines is intended to be used by skilled personnel to weld metal, plastics, etc. The main areas of use are: goldsmith (welding of precious metals), dental technician (welding and repairing medical devices), industrial (modified moulds), automotive and artisan.

- Do not try to weld artefacts that may contain materials that are not in the recommended list
- Only use ELETTRROLASER S.r.l. parts and consumables.
- Contact ELETTRROLASER S.r.l. support for assistance.
- Once consumables are worn they must be replaced.
- Follow all the instructions and safety regulations in this manual.

WHAT MUST NOT BE DONE

- Do not modify the equipment.
- Do not try to weld artefacts that include any of the following materials: beryllium, uranium, plutonium, cadmium, magnesium, sodium, potassium mercury, lead and arsenic.

TECHNICAL SPECIFICATIONS

- Do not place combustible materials along the laser beam path.
- Do not use materials that emit toxic or explosive gases.
- Do not stare at the laser beam without eyewear.
- Do not leave clothes on the LASER trajectory.
- Do not place living or dead organisms (such as animals) in the laser beam path.
- Do not use the welding laser to heat food.
- Do not use the laser welding machine to dry clothes and materials in general.

TECHNICAL SPECIFICATIONS

SPECIFICATIONS	DESCRIPTION
Supply VAC	230/110
Supply system <i>no. of phases</i>	1
Frequency <i>Hz</i>	50-60
Average power absorbed <i>KW</i>	1,8
LASER crystal <i>type</i>	Nd: YAG
Wavelength <i>nm</i>	1.064
Pulse duration <i>msec</i>	1-6
Duty Cycle	0-100%
Spot LASER Dimensions <i>mm</i>	0,2-1,5
Type of cooling	Liquid
Internal fuse	16 AT
Weight <i>Kg</i>	15
Dimensions <i>cm</i>	340X340X340
SPECIFICATIONS	DESCRIPTION
Working environment temperature $^{\circ}\text{C}$	17-35
Maximum operating humidity %	65
Noise level <i>dB (A)</i>	<70

HOW IT WORKS

DADO (figure 7) is a compact laser welding machine that is easy to transport. Thanks to its practicality and dynamism, it can be used wherever there is an electrical socket.

The machine is managed directly from a smartphone/tablet thanks to the dedicated application.

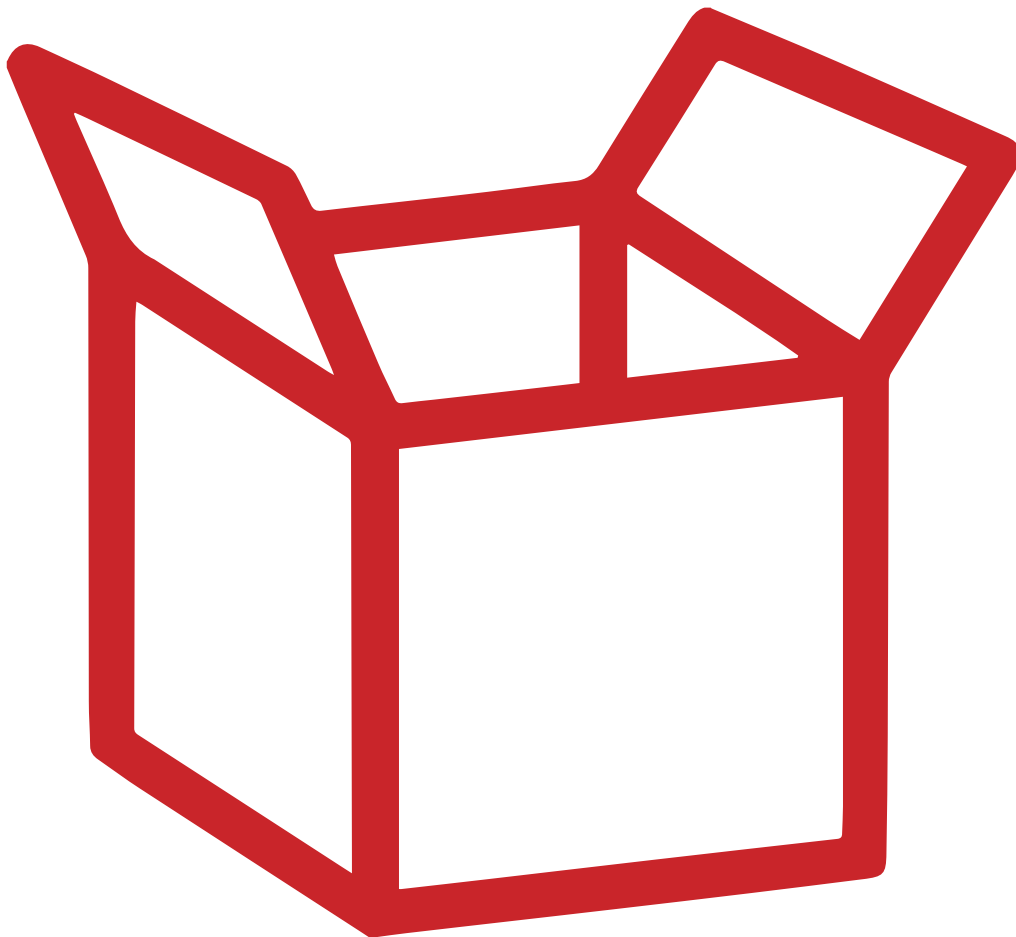

Figure 7 - Dado

INSTALLATION



DADO is easily installed but a few basic rules must be followed. Unpack the machine carefully and prepare for installation.



CAUTION: when you open the box and start to unpack the machine, be careful not to damage it; ELETROLASER S.r.l. disclaims any liability for damage caused by carelessness and negligence in unpacking the machine.

CONTENTS OF THE BOX

Once the box has been opened, the following accessories will be found packed separately, which must be assembled:



DADO WELDING MACHINE



BINOCULAR



BOTTLE WITH COOLANT



GLASS FIBRE BRUSH



METAL TWEEZERS



PEDAL WITH CABLE

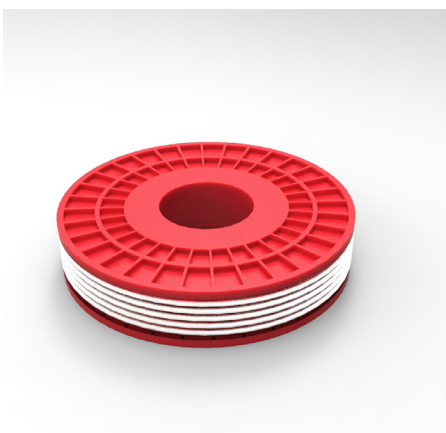

SILVER WIRE COIL



2.5 mm HEX KEY



CLOTH

UNPACKING THE MACHINE

Unpack the machine by paying attention not to damage the machine.

Once the box has been opened, proceed as follows:

1. Place the power cable and the pedal near the base of the box
2. Remove the top part of the packaging
3. Remove the machine from the box and place it on a worktop
4. Remove the binocular with its packaging and the bottle with the coolant from the welding chamber
5. Assemble the accessories
6. Pour the coolant into the machine
7. Connect the plug



Figure 8 - Unpacking Dado

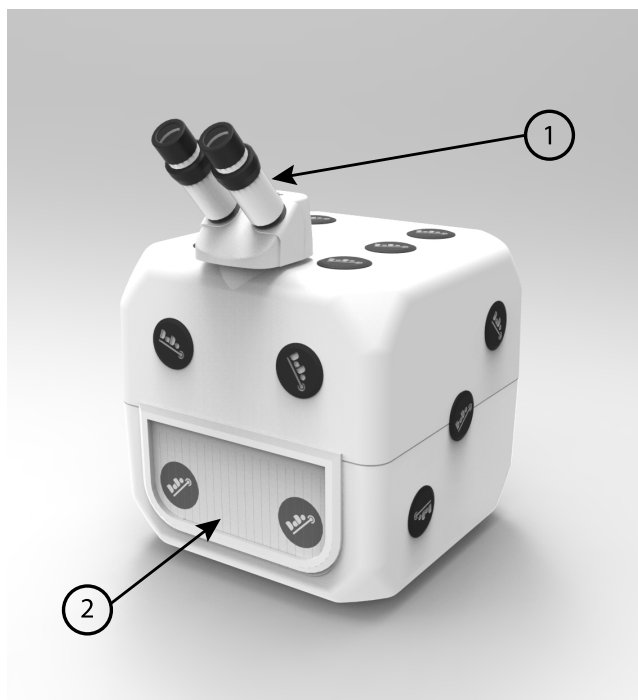

Figure 9 - Positioning of the controls

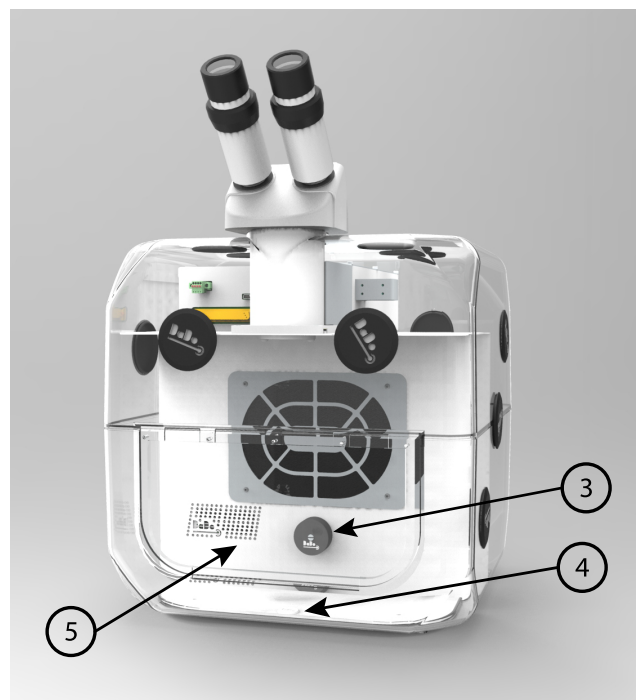

Figure 10 - Positioning of the controls

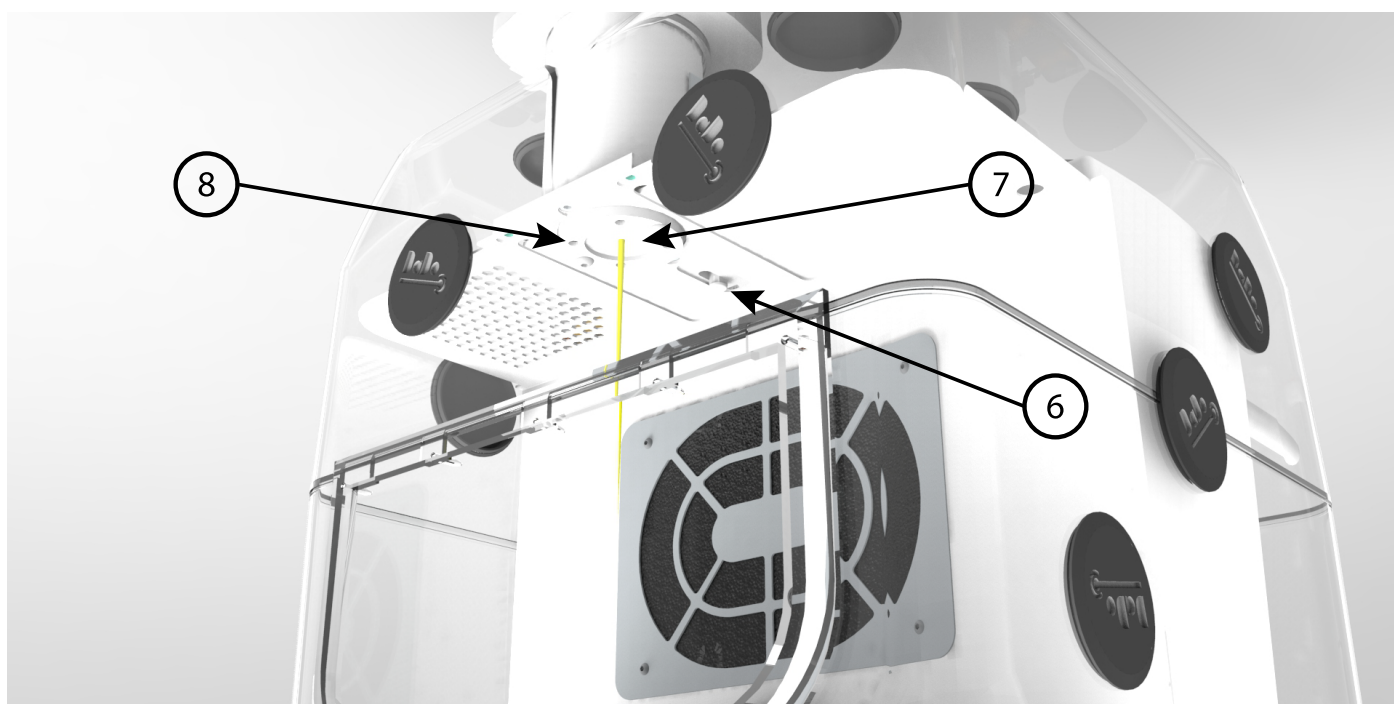

Figure 11 - Positioning of the controls

1. Binocular
2. Leather fringe
3. Adjusting knob
4. Ceramic
5. Welding chamber
6. Beam expander adjusting knob
7. Protection glass
8. Point alignment adjusting screws

ASSEMBLING THE ACCESSORIES

Before starting to assemble the accessories, make sure that the machine is positioned in a closed room with an appropriate ventilation system.

The only accessory to be mounted is the binocular that you extracted from the opening of the machine welding chamber (figure 12). Remove the binocular from the packaging and place it on the machine as shown in figure 13. Centre the binocular and use the Allen key supplied with the machine to tighten (not excessively) the screw that secures the binocular (figure 14). In the packaging of the binocular there are also two eyecups to apply to the eyepieces if spectacles are used during welding.

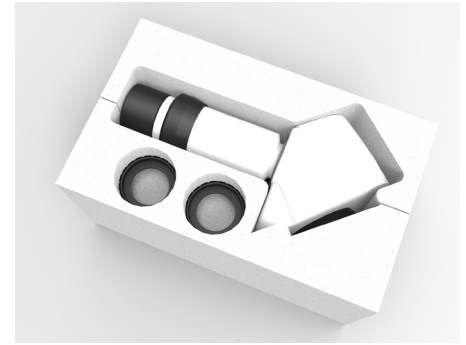

Figure 12 - Packaged binocular

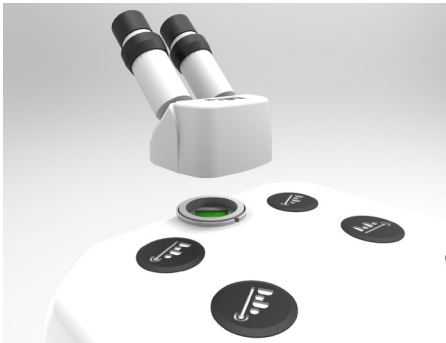

Figure 13 - Positioning of the binocular

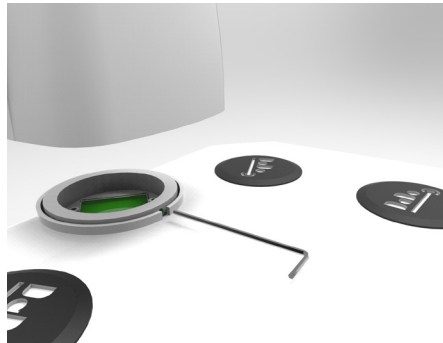

Figure 14 - Binocular locking screw



Figure 15 - Aligned binocular

ADDING COOLANT

- Remove the cap on the top left from the back of the machine as shown in figure 16.
- Make the pipe with the red cap come out.
- Take the bottle with the coolant, open the hole in the bottle spout with a cutter.
- Connect the bottle to the hose as shown in the figure below and pour in the entire contents (1lt).
- Plug the hose with the red cap (supplied) and fold it down and insert it into the machine in the initial position.
- Replace the cap with the dado logo and the machine is ready.

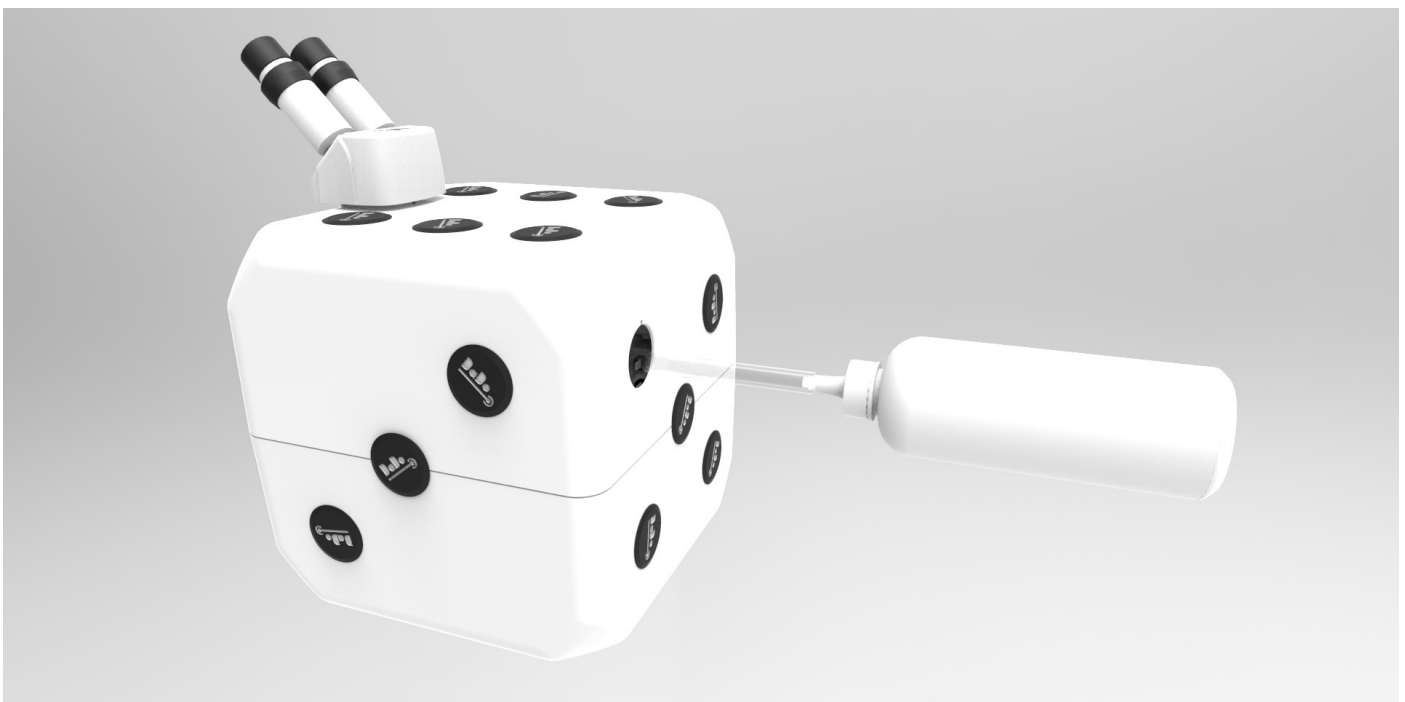

Figure 16 - Adding coolant

POSITIONING OF THE CONTROLS

The DADO welding machine is very simple and intuitive to use and therefore, has few controls which are used to set the machine parameters and perform some control operations on it.

There are 3 machine controls:

- Adjusting knob: which can be either rotated or pressed. Depending on the duration of the pressure and if actuated together with the pedal, it can have different functions (figure 22).
- Pedal: used to actuate the laser for welding and together with the knob pressure, parameters can be changed or other useful machine functions will be available (figure 23).
- Application: this is basically the machine's main control; through this application you can change the machine parameters, solve temporary machine problems and customise some settings. Furthermore, in addition to the various sound and visual warnings that the machine emits, the application provides the machine state in real time (figure 24).

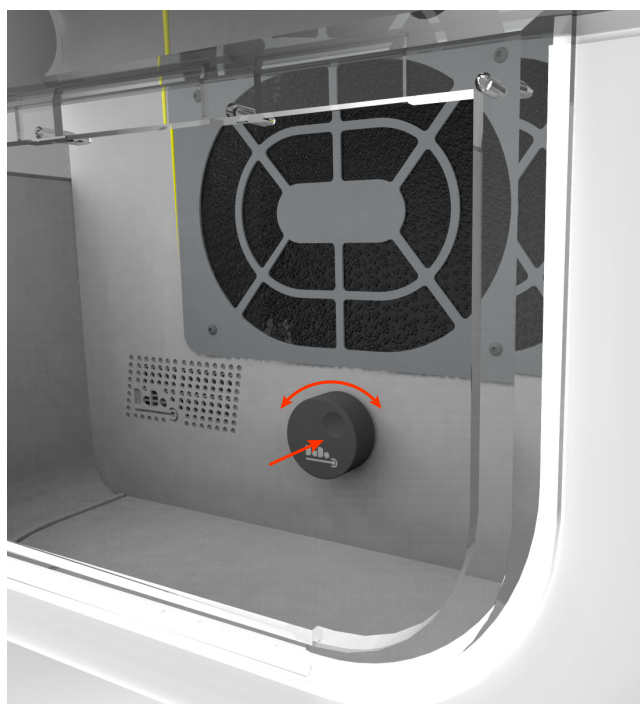

Figure 17 - Adjusting knob



Figure 18 - Pedal

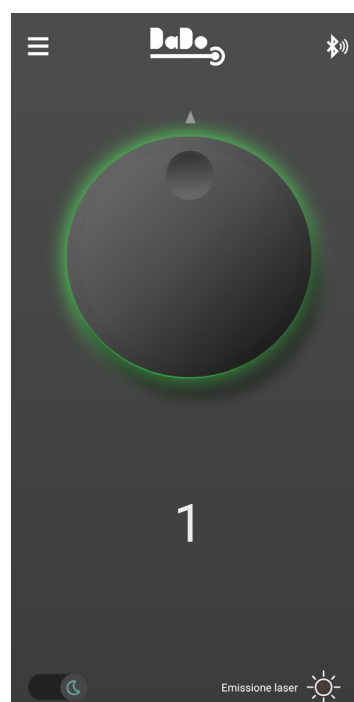
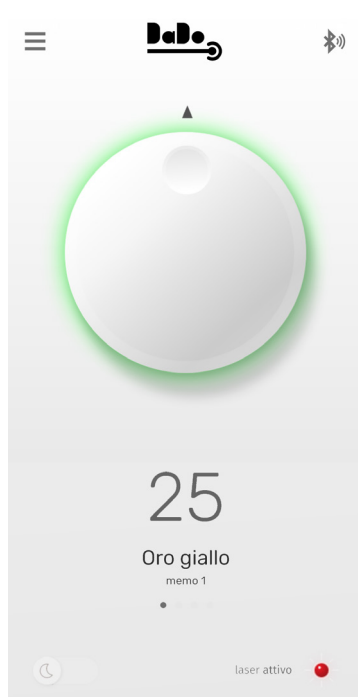

Figure 19 - Application home screen (day and night version)

APPLICATION CONTROLS

Through the application you can access all the machine functions by setting the parameters as you wish, depending on the type of welding.

MENU

A docked window with other clickable sub-menus inside will appear from the left side when the Menu icon is pressed:

- HOME
- MEMORIES
- INFORMATION
- SETTINGS
- CONTACTS

HOME SCREEN

Press the HOME icon to go back to the home screen where the following are found:

- MENU ICON (top left highlighted in RED in figure 20). Press the icon for the menu shown in figure 21 to appear.
- SWITCH - button with the moon icon on top at the bottom left corner of the display (highlighted in GREEN in figure 20) that is used to go from the screen with a white background for well-lit environments to the screen with a black background for environments with poor light. Depending on what smartphone/tablet is used, this function can be used by means of the twilight sensor of the device that the application is installed on.
- LASER INDICATOR - characterised by a dot that indicates the state of the laser and is positioned at the bottom right of the display (highlighted in ORANGE in figure 20). The dot can be GREEN when the laser is not running, STEADY RED when the laser is ready for welding and FLASHING RED when the laser is used for welding.
- INTERACTIVE KNOB - at the centre of the screen (highlighted in YELLOW in figure 20) it allows the welding parameters to be selected from the 12 pre-set settings.
- MEMORY CELLS - 4 settings can be saved in addition to the 12 pre-set settings, according to your needs. A "sweep" action on the HOME screen, under the interactive knob, allows you to select the desired setting. The name of the setting and the memory position will appear (highlighted in BLUE in figure 20).

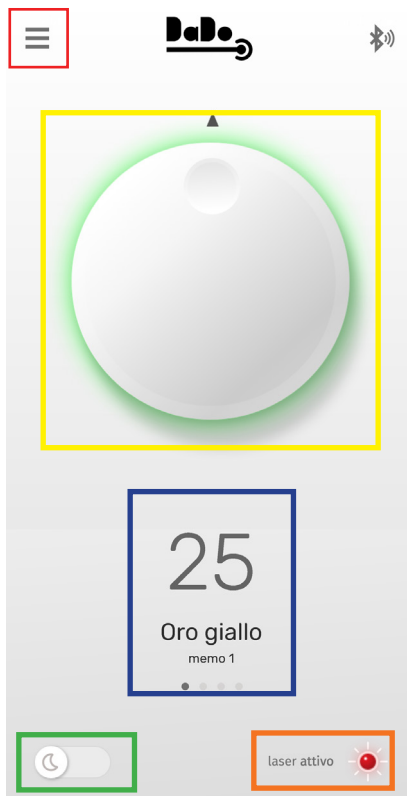

Figure 20 - Home screen controls

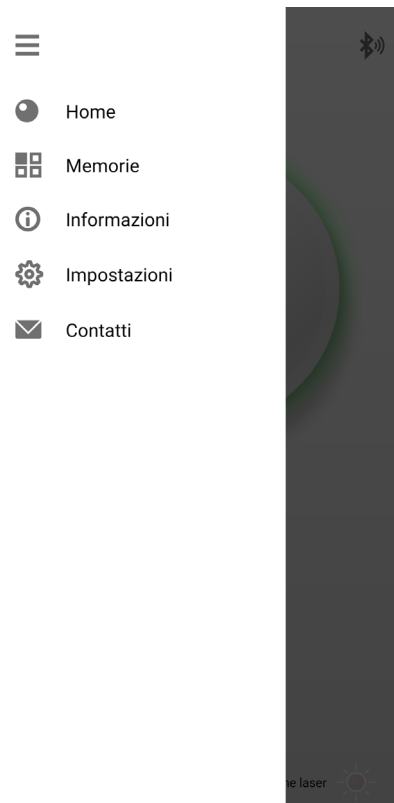

Figure 21 - Drop-down menu screen

MEMORIES SCREEN

Press the MEMORIES icon that appears on the drop-down menu of the home screen to access the screen where you can save your personal welding settings (figure 22).

INFORMATION SCREEN

Press the INFORMATION icon to access the page where you can find all the information concerning the machine, its components and machine status in real time (figure 23).

SETTINGS SCREEN

Press the SETTINGS icon to manage some machine functions and the application, such as the option of viewing the promotional banners, the vibration of the tablet/smartphone when there are warnings to be displayed, the stand-by time of the machine and the volume of the sound alerts (figure 24).

CONNECTIONS SCREEN

Press the BLUETOOTH icon on the main screen for the list of paired and ready-to-pair devices. Click on the name of the relative device to connect to it (figure 25).

CONTACTS SCREEN

Click on the CONTACTS icon for information about the manufacturer and the relative contacts to communicate with them, if necessary (figure 26).

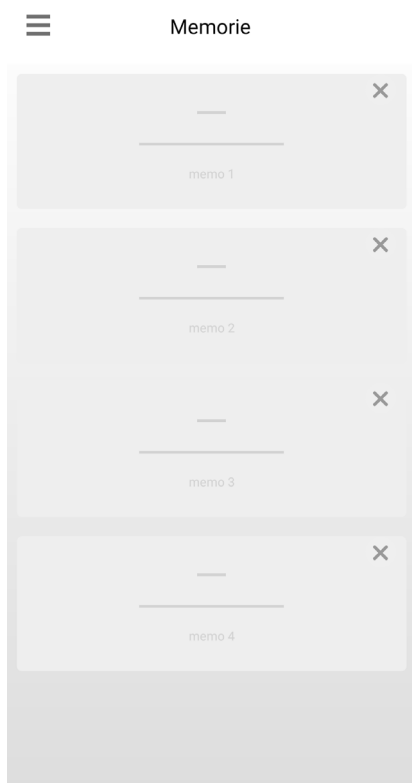

Figure 22 - Memories screen

The screenshot shows the 'Informazioni' screen with a hamburger menu icon in the top left. The screen displays a list of machine status and parameters:

Spari macchina	202
Spari lampada	202
Firmware macchina	152
Stato macchina	Emissione laser
Allarmi in corso	0
Temperatura H2O	42
Temperatura PFC	60
Temperatura IGBT	49
Numero Seriale	102
Numero rivenditore	0

Figure 23 - Information screen

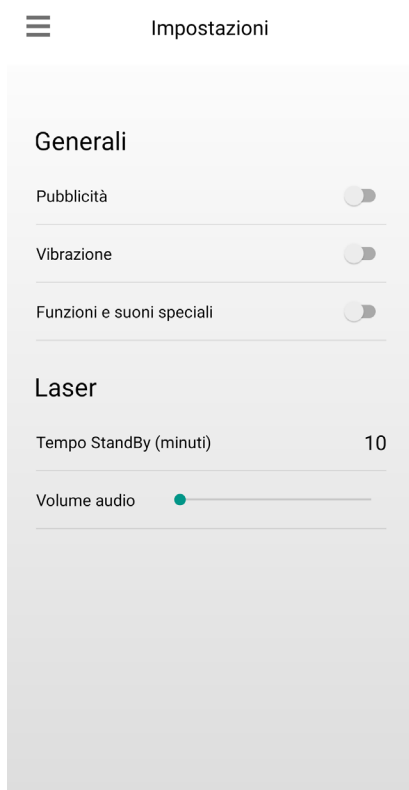

Figure 24 - Settings screen

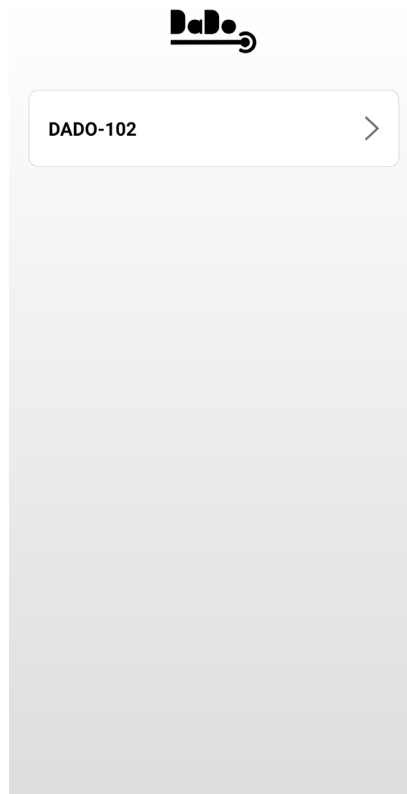

Figure 25 - Connection screen



Figure 26 - Contacts screen

FIRST START-UP

Once the machine has been unpacked, the accessories are assembled and the preliminary operations carried out, we can proceed with the first machine start-up.

- Download the application from the store of the device you want to use and install the application.
- Connect the power cable to the power socket. Once the electrical power is received, the machine immediately enters STAND-BY mode and this state is characterised by a sound and blue light that the LEDs inside the welding chamber will emit.
- Prepare the machine for welding by pressing the adjusting knob found inside the welding chamber. At this point the machine performs a preliminary check and if there are no anomalies and/or problems, the machine will emit a sound to warn that the laser is ready for welding. The LEDs will emit a white light that indicates there are no anomalies and/or problems.

MACHINE SWITCH-OFF

Switch the machine off by simply removing the plug from the power socket and set the machine in STAND-BY mode by pressing the adjusting knob for 3 seconds until the LEDs turn blue and you hear the mode switch sound.

NOTE: Breaking or removing seals affixed to the laser system by the manufacturer **immediately renders the warranty on the entire welding system null and void.**

WELDING WITH DADO



**By following a few step-by-step instructions
you will be ready to use DADO and start a new
welding experience**



CAUTION: if you have never welded with laser technology, it is advisable to contact the machine manufacturer who can provide a welding course to learn how to weld with DADO.

LASER WELDING PHYSICAL PRINCIPLE

The physical principle behind the generation of laser light is the phenomenon of stimulated light emission. LASER, in fact, stands for Light Amplification by Stimulated Emission of Radiation. This means that the laser consists of light that is amplified by rapid photonic emission, originated by a first photon (light particle) that interacts with an excited atomic system and stimulates the emission of two photons which in turn interact with other atoms, thereby leading to an avalanche effect.

The excitation of the atomic system requires an external supply of energy, in a suitable form to be able to trigger the laser effect. "Optical pumping" is obtained when the light emitted by a light source impacts the active material (material that can emit laser light) and causes the atoms to be excited by the light energy being absorbed.

The amplification of the laser effect is obtained by crossing the active material several times by the same light it emits. This is achieved by interposing the active medium between two opposing mirrors, i.e. constructing and "aligning" what is called a "resonator". When the resonator is perfectly "aligned", the crystal and the mirrors are centred on the optical axis. The sides of the crystal, the front mirror and the face of the rear mirror closest to the crystal are parallel. The laser energy extraction of the resonator is maximum in this optical configuration and the beam is circular and of approximately even intensity. After being amplified, the laser beam will be concentrated by a focus lens that can have different focal lengths and can be deflected inside the welding chamber by a 45° mirror. This way, the energy will be concentrated in a few tenths of a millimetre, allowing metals to be melted in that point.

The energy intensity that the laser can concentrate is 800-1000 KW/cm. As a comparison, it can be said that if the sun's rays are focused with the same lens, they would provide an energy intensity of 0.5 KW/cm.

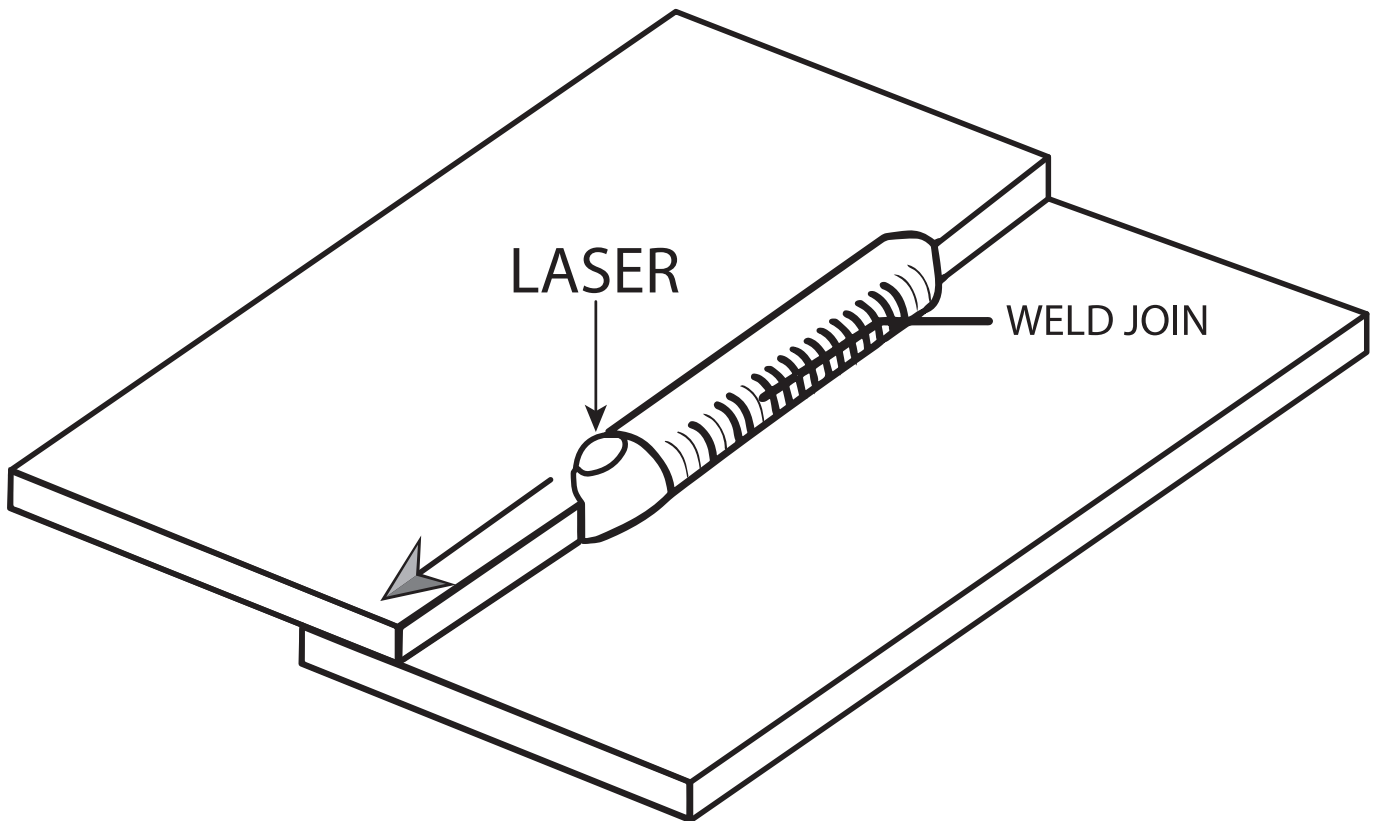

Figure 27 - Laser welding diagram

LET'S START WELDING

Once the coolant is added into the machine and the application is installed on the tablet/smartphone, follow these step-by-step instructions to start welding:

1. Plug in the power supply, a sound will indicate that the machine is in STAND-BY mode and the LEDs of the welding chamber will turn BLUE.
2. Press the adjusting knob found inside the welding chamber for the machine to run a CHECK on the system, and if there are no problems it will be ready for welding.
3. Adjust the binocular. The adjustment of the binocular requires particular attention because if this is done incorrectly, it can compromise the whole focusing process and consequently, welding. In the right eyepiece block there will be a cross which will then be aligned with the laser to start welding in a correct position.
 - 3.1 First place the adjustment of the eyepiece blocks on the neutral dioptré and then do this for both blocks. If the eyepiece blocks are placed on different dioptrés, it will be difficult to have precise and regular focus (figure 28).
 - 3.2 If spectacles are used do not use the supplied eyecups, but if spectacles are not used, we recommend using the supplied eyecups. On the right side of figure 29 there is the dioptré without eyecup, whereas on the left side the dioptré has the eyecup installed.
 - 3.3 Place an object under the lens at a height that is in focus and then adjust the width of the binocular (figure 30) to have a single circle without shadows and with a clear view when looking inside it.
4. Position the piece to be welded in the welding chamber, centring it with the pointer according to where you want to weld.
5. Use the application or the adjusting knob to select one of the 12 pre-settings. It is advisable to run a few preliminary welding tests on a sample of the material to be welded to find the right setting of the welding parameters among the preset ones.
6. Press the pedal and start welding.

ENJOY YOUR WORK



Figure 28 - Dioptré



Figure 29 - Dioptré with and without the eyecup



Figure 30 - Binocular

**TROUBLESHOOTING
ANOMALIES
MAINTENANCE**



This chapter describes the basic issues and maintenance for your DADO.

Contact customer support for details and important issues.



ERROR MESSAGES

The error messages that may appear on the display are listed in the table in figure 31:

ER.N°	MESSAGE	CAUSE	SOLUTION
01	SIMMER ERROR	The Laser lamp does not light up	<p>A. Check the fuse</p> <p>B. Contact TECHNICAL SUPPORT</p>
02	STOPPED COOLANT	<p>The coolant does not move inside the cooling tubes</p> <p>A. Stopped pump</p> <p>B. Dirty or cloudy water</p>	<p>A. Check the fuses and contact TECHNICAL SUPPORT</p> <p>B. Check the colour of the coolant from the slots and if there is debris residue at the bottom of the bottle. In this case, replace and clean the cooling system</p>
03	HIGH COOLANT TEMPERATURE	<p>The coolant has reached the guard temperature of 55°:</p> <p>A. High work cycle of the machines</p> <p>B. Insufficient liquid inside the bottle</p> <p>C. Stopped side cooling fan</p> <p>D. Too much dust or dirt deposited on the heat pump</p>	<p>A. Wait 15 minutes with the machine switched on until the error disappears; otherwise, contact TECHNICAL SUPPORT</p> <p>B. Check that there is liquid in the tank from the side and add distilled water, if necessary</p> <p>C. Check that the fan works properly, which should turn very quickly in case of error 01, making a certain noise. Otherwise, contact TECHNICAL SUPPORT</p> <p>D. Blow compressed air through the slots to remove dust from the exchanger. Do not open without first calling and consulting TECHNICAL SUPPORT</p>
04	HIGH ELECTRONIC TEMPERATURE	<p>The internal thermostat of the power electronics has detected a high temperature</p> <p>A. High work cycle</p> <p>B. Dust or dirt deposited on the rear cooling fans</p> <p>C. Stopped rear fans</p>	<p>A. Wait a few minutes for the error to disappear and allow the machine to rest for about 20 minutes.</p> <p>B. Use the compressed air to blow inside the slots on the rear panel to see if there is dust or any other deposits on the fans. Contact TECHNICAL SUPPORT before opening it.</p> <p>C. Contact TECHNICAL SUPPORT</p>
05	RELAY INPUT	<p>The machine is on but is not welding</p> <p>A. Problems with the power supply</p>	<p>A. Check the power supply connections</p> <p>B. Replace the power supply</p>
06	LOW CAPACITOR VOLTAGE	<p>The electronics have not charged the capacitor bank</p> <p>A. The generator is broken</p>	<p>A. Contact TECHNICAL SUPPORT</p>

Figure 31 - Table of errors

The table in figure 32 lists anomalies and their possible solutions.

If a fuse must be replaced, do so with one of the same amperage and same type of intervention. We recommend using fuses that are supplied with the machine. Contact technical support for any clarification.

PROBLEM	RESOLUTION
The machine goes on but does not go to the START position	<ul style="list-style-type: none"> ➤ Check the position of the key inside the welding chamber
The display indicates the parameters but the laser does not shoot	<ul style="list-style-type: none"> ➤ Check the connection of the machine with the pedal
In the microscope I see that the shutter closes the view and becomes dark but there is no effect on the welded piece	<ul style="list-style-type: none"> ➤ Power and time set too low ➤ MS5 zoom drum in incorrect position ➤ Position glass is dirty (see chapter 7 MAINTENANCE)
The welding lights do not come on	<ul style="list-style-type: none"> ➤ Check the position of the knob to adjust the intensity inside the chamber ➤ Check the fuses
When I shot, the smoke created by welding rises towards the microscope, blurring the vision	<ul style="list-style-type: none"> ➤ The filter on the internal fan of the welding chamber is too dirty ➤ The fan is stopped: check the fuse
The protective gas does not come out when I press the pedal	<ul style="list-style-type: none"> ➤ Check on the display that the gas countdown is enabled ➤ Check that the inlet pressure is not higher than 2 Bar ➤ Check the flow regulator inside the welding chamber ➤ Check that there is no foreign object in the rear connection blocking the passage
The laser does not come on	<ul style="list-style-type: none"> ➤ Check that the switch on the back is in the ON position ➤ Check that the emergency push-button inside the welding chamber is released ➤ Check the fuses ➤ Check the connection to the mains

Figure 32 - Table of anomalies

REPLACING THE AR/AR PROTECTION GLASS

Whenever the protection glass is “dirty”, the power output decreases. Therefore, when there is a strong concentration of metal splashes on its surface, replace the glass.

Regularly check the microscope lens protection glass found inside the welding chamber. This special anti-reflective glass @ 1,064 nm is secured with an aluminium locknut.

Replace the special protection glass sheet as follows:

- Take the screws (Ref.A B figure 33) out of the supporting locknut;
- Detach the locknut (Ref. C Figure 33) from the optical body and then take out the glass.
- Wipe the surface with a soft, non-abrasive cloth.
- Do not attempt to remove any metal splashes on it.
- Reinsert the new/clean glass in its housing and carefully position the locknut, tightening it with the two screws (Ref.A B figure 33).

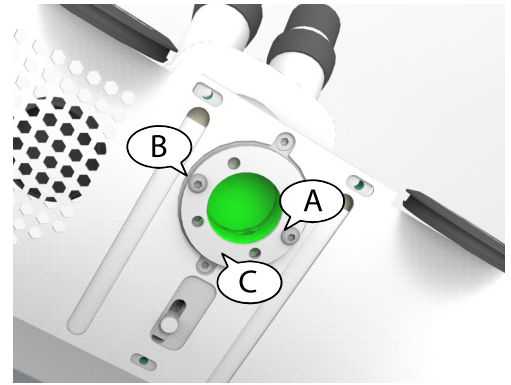

Figure 33

CAUTION: It is advisable to replace the protection glass if there are metal splashes on it, because the pulses generated by the LASER could overheat further, potentially causing the glass itself to break.

ALIGNING THE AIMING CROSS

The welding aiming cross may not be aligned with the actual shot point. This could occur every time the welding machine is moved or raised.

Even a microscopic bump could create the misalignment of the aiming cross from the actual shot point. These small optical defects can in any case be compensated by an adjustment made by the user.

First align the stereomicroscope then unscrew it just from its base using the 2.5 mm Allen screwdriver (supplied), and once pushed firmly against the front edge of its base, in other words in the opposite direction to the user, screw it firmly until it is permanently immobilised in this position.

Adjust the cross alignment using a 3 mm Allen key to reach its 3 adjusting screws (Figure 34). Therefore, to check the alignment, place a piece of sheet metal inside the welding chamber in a stable position, in focus. Then hit the previously placed sheet with a single low-power shot.

Then, looking inside the microscope, turn screws 1 and/or 3 creating very little movements (Figure 36) until the cross is on top of the point where the shot hit the sheet. It is important to move only one screw at a time since they move distinctly. Screw 1, in fact, allows vertical adjustments (or in the north-south direction), whereas screw 3 corrects the horizontal displacement (or in the east-west direction). SCREW 2 REMAINS FIXED AND MUST NEVER BE TOUCHED, OTHERWISE YOU CAN COMPROMISE THE ENTIRE ALIGNMENT SYSTEM.

Then act progressively on these screws, alternating the action on one and the other, as many times as is necessary for both (the aiming cross in focus on the object, and the focus point of the shot) to match up perfectly or to be virtually and accurately on top of each other.

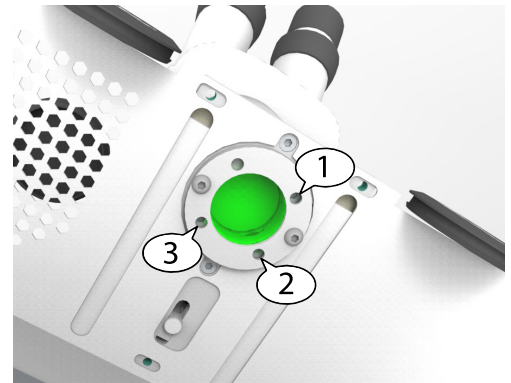

Figure 34

CAUTION: During the alignment phases, pay attention to the position of the hands that could interfere with the passage of the LASER.

CAUTION: Always approach the alignment point with small movements and keep the test sheet very stable. NEVER FULLY UNSCREW THE ADJUSTING SCREWS AND DO NOT TOUCH SCREW 2 SHOWN IN FIGURE 34.

CHANGING THE COOLANT

- Remove the top left cap from the back of the machine as shown in figure 35.
- Extract the pipe with the red cap and remove said cap.
- Grab a container to collect the coolant to be replaced and direct the pipe towards it.
- Start the emptying circuit of the refrigerant circuit.
- Connect the bottle with the “new” coolant to the hose as shown in the figure below and pour the entire contents.
- Plug the hose with the red cap (supplied) and fold it down and insert it into the machine in the initial position.
- Replace the cap with the dado logo and the machine is ready.

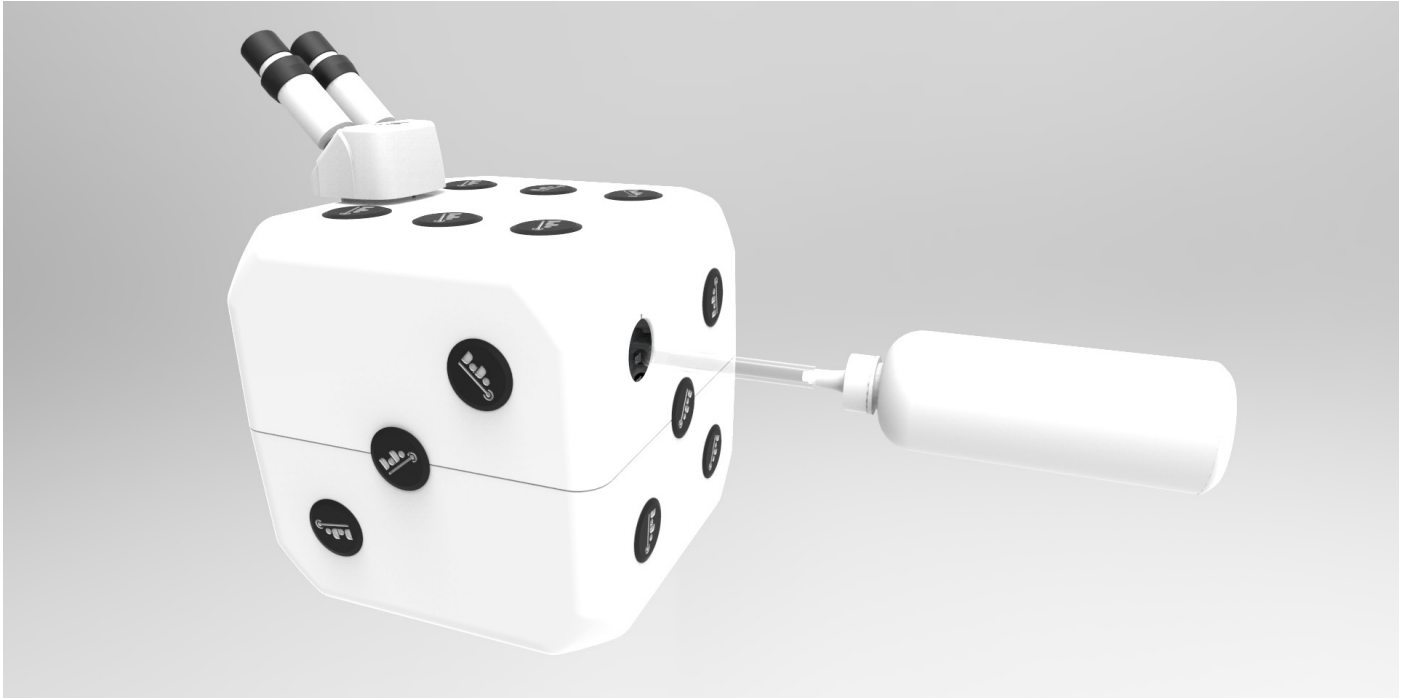

Figure 35 - Adding coolant

In order to solve any technical or other problem, please contact the company:

ELETTROLASER S.R.L.

Via Dell'Industria, 35

37060 SONA (VR)

TEL. +39 045 6082415 / FAX +39 0456088650

EMAIL info@elettrolaser.com

WEB www.elettrolaser.com

Technical support is available from Monday to Friday from 8:30 am to 12:30 pm and from 2:00 pm to 6:00 pm.

TERMINOLOGY

International regulations have standardised the terminology related to lasers, their components, accessories, performance, etc. The particularly significant definitions and references to applicable industry regulations are described below.

Definition according to European standard EN 12626 (ISO 11553) Safety of machinery; Laser processing machines.

1. **MACHINE** - assembly of linked parts or components, at least one of which moves, with the appropriate actuators, control and power circuits, joined together for a specific application, in particular for the processing, treatment, moving or packaging of a material.
2. **LASER SYSTEM** - Machine in which (an) embedded laser(s) provide(s) sufficient energy/power to melt, evaporate, or cause a phase transition in at least a part of the workpiece, and which has the functional and safety completeness to be ready-to-use
3. **MANUFACTURER** - Individual or organisation that assembles the laser processing machine
4. **COMPLEX COMPONENT** - Element used to set up equipment, but which cannot be considered an apparatus in itself since it does not have an intrinsic function for the final use.
5. **INSTALLED SYSTEM** - Assembly consisting of several devices and/or systems combined in such a way as to achieve a specific objective but not intended to be placed on the market as a single commercial unit.
6. **ELECTROMAGNETIC COMPATIBILITY** - suitability of a device, equipment or a system to function in its electromagnetic environment satisfactorily, without introducing unacceptable electromagnetic disturbances to everything in that environment, including both the emission requirements (interference produced by the device) and immunity (insensitivity of the device) to disturbances produced by the environment.
7. **SECOND ENVIRONMENT** - Environment that includes all industrial utilities other than those connected directly to a low voltage power network that supplies buildings used for domestic purposes.
8. **IN SITU** - Environment in which the equipment is installed for normal use by the end user and in which the equipment is to be tested.
9. **RESTRICTED DISTRIBUTION** - Marketing method in which the manufacturer limits the supply of equipment to suppliers, customers or users who, separately or jointly, have the technical competence of the requirements related to E.M.C. for the installation of electrical and electronic equipment and which, by exchanging technical specifications, takes the "in situ" measurements of the actual boundary conditions.

Reference documents and sector regulations

2004/108: Electromagnetic compatibility directive

2006/42/EC: Machinery directive: essential safety requirements

2006/95/EC: Low voltage directive

EN 60825-1: Standard for the safety of laser products

EN 61000-6-1: Electromagnetic compatibility. Part 6-1: Immunity for residential, commercial and light-industrial environments.

EN 61000-6-3: Electromagnetic compatibility. Part 6-3: Emission standard for residential, commercial and light-industrial environments

EN 60204-1 – Part 1: Equipment safety, Electrical equipment of industrial machines

COMPLIANCE WITH EEC DIRECTIVES AND CE MARKING

CONDITIONS FOR COMPLIANCE WITH THE EMC DIRECTIVES OF THE DADO LASER SOURCES
Conformity of the Laser sources defined in the heading of this paragraph with the Directives on Electromagnetic Compatibility is only valid for the conditions listed below.

1. THE SOURCES DEFINED IN THE TITLE OF THIS PARAGRAPH ARE COMPLEX COMPONENTS SOLD TO BE INCLUDED AS A PART OF AN INSTALLED EQUIPMENT OR SYSTEM: THEREFORE THE OPERATING CONDITIONS OF THE SOURCE WITHIN THE SYSTEM MUST BE THOSE WHICH ARE PRESCRIBED IN THE PARAGRAPH OF THIS PUBLICATION.
2. THE SOURCES DEFINED IN THE TITLE OF THIS PARAGRAPH ARE MARKETED ACCORDING TO A RESTRICTED DISTRIBUTION SYSTEM; THEREFORE THE INSTALLER AND/OR THE USER ARE AWARE OF THE REQUIREMENTS CONCERNING MATERIAL THAT IS ELECTROMAGNETICALLY COMPATIBLE.
3. THE SOURCES DEFINED IN THE TITLE OF THIS PARAGRAPH MUST BE INSTALLED ACCORDING TO THE INSTRUCTIONS OF THIS PUBLICATION AND THE STIPULATED REQUIREMENTS MUST BE STRICTLY COMPLIED WITH, INCLUDING ON-SITE VERIFICATION OF THE FINAL SET UP WITH RESPECT TO THE DIRECTIVES.
4. THE SOURCES DEFINED IN THE TITLE OF THIS PARAGRAPH ARE ONLY INTENDED FOR USE IN THE SECOND ENVIRONMENT.

DECLARATION OF CONFORMITY

ELETTROLASER S.r.l. declares that, under the conditions specified in this document, the DADO source: conforms with the EU Directives on LOW VOLTAGE.

NOTE FOR THE APPLICATION OF OTHER EEC DIRECTIVES

LASER sources are not subject to other EEC Directives besides those indicated in paragraph 2. However, for reasons related to application, references are made to other Directives; in particular, to comply with the requirements of Machinery Directive 2006/42/EEC, and the declaration of incorporation is indicated below.

DECLARATION OF THE MANUFACTURER

WITH REFERENCE TO THE MACHINERY DIRECTIVE REQUIREMENTS, ELETTROLASER S.r.l. declares that the DADO source must be installed according to its own instructions and must not be commissioned before the machines that they will be incorporated into have been declared as compliant with the above mentioned Directive.

GENERAL SAFETY REQUIREMENTS DURING WELDING



When the problem of checking the safety of a system arises, the first step is to identify the potential dangers related to the operation of the system itself.



If LASER equipment is installed on board the system, in addition to the regular Hazards deriving from the type and operating mode, another Hazard must be considered that is represented by the LASER Radiation (electromagnetic radiation, mainly infrared).

The safety of this type of Equipment is subject to specific Standards, both from electrical and radiation (non-ionised) aspects.

It follows that careful observance of the technical advice offered by the specific Standards, leads to reducing the Risk of accessing the Danger at levels that are presumably compliant with intention of the Legislator.

Observance of the Standards is therefore equivalent for the Manufacturer of the LASER Source and the Integrator of the Source in the System and the System User.

It is therefore understood that there is no single way to increase safety, since various protection systems can be identified.

PROTECTION SYSTEMS

The following general rule must be observed "... where there is danger there must be no Man and where there is Man there must be no danger ...".

With this, it is immediately clear that the main path to follow is that of placing a barrier between man and danger that minimises the risk of accessing the danger itself. Another way is to install a number of warning measures that inform people of the existence of the danger, preventing them from coming into unintentional contact with the danger. Lastly, the need for personal protective measures remains, for any situation in which the risk may vary according to the operating conditions.

Three types of protective measures have been identified for LASER equipment:

- A. Engineering Devices
- B. Procedural and Administrative
- C. Personal Protection

ENGINEERING DEVICES

These are the most appropriate measures for an industrial environment and consist of a number of precautions that, already in the design, construction and integration phases of the system, consider the existing hazards and devices to minimise the risk. When applicable, this is achieved by equipping the system with appropriate enclosures that enclose both the LASER and the work area, preventing the dangerous radiation from reaching outside the enclosure itself.

This way, the acceptable emission limit (AEL) is reduced to a level that a LASER classified as hazardous (Class IV) does not outwardly emit radiation exceeding the level of Class I, which is considered not dangerous.

REGULATORY REQUIREMENTS ON GUARDS

The guards or barriers or enclosures must intercept the infrared radiation emitted by the LASER and resist perforation.

This requirement is easily achievable (for low power LASERS) by using sheet panels that fully shield the radiation and indefinitely resist perforation by radiation not focused on them. High power LASERS require a necessary perforation time to be established between one inspection and the next or active enclosures must be used, which can feel the perforation (through gaps and adequate sensors).

NdYVO4 is sufficient protection for Nd-Yag Laser equipment, and is made of metal material with a thickness greater than 1.5 mm to indefinitely resist non-focused laser radiation of the incorporated Laser source.

Access panels and safety locks must be designed so as not to allow access to the hazardous radiation. Enclosures or panels must be removed depending on the type of processing and/or intervention on the process. These removable Panels must be equipped with safety locks in this case and if the panels are not secured to the structure with screws that are removed with special tools, so as to reduce radiation to permitted levels when the panels are engaged.

This is generally accomplished through electrical interlocking with the power supply of the LASER energising system.

The interlocking device protects people and must conform and be approved for such use.

The optical lenses must contain specific attenuators able to prevent human access to radiation that is higher than class I AEL. Often, the problem that arises is that of having an inspection window to observe the interaction between the LASER beam and the material being processed. In this case, the windows must incorporate sufficient optical density (OD) to reduce the radiation to non-hazardous levels. The calculation of the necessary OD must consider the type of laser, its operation, the distance from the focal point, the viewing direction, the exposure time, etc. The filter must be approved and certified since it protects people.

PARTICULAR REQUIREMENTS FOR CLASS IV LASERS

Remote control, key command, emission warning and the attenuator are prescribed for class IV LASERS. These LASERS require the Manufacturer to provide the User with a measure that allows an external safety to be easily added to the LASER itself. This is achieved with the remote blocking connector, that is a contact that blocks or reduces the laser emission if it is opened.

The start-up device must prevent unauthorised personnel from operating the LASER. For this purpose, a removable key command is used in the off position.

When LASER radiation is active, people must be informed of its presence. In this case, an emission warning is emitted (usually a red flashing light).

Lastly, a medium must always be present to stop the LASER beam temporarily. This is achieved by the source Manufacturer with a shutter or beam attenuator.

POSITIONING CONTROLS AND PLATES

According to the requirements, the controls must be placed in an area where radiation cannot be accessed and where appropriate warning labels must be affixed clearly visibly for people.

USER REQUIREMENTS; ADMINISTRATIVE PROCEDURES AND STANDARD OPERATING PROCEDURE (SOP)

The user requirements that must be complied with for the Laser equipment to be used correctly are important so as not to nullify the safety-related efforts of the Manufacturer and force the User to be responsible for using the protections set up by the Manufacturer correctly with the addition of those that fall under their competence with also the obligation of developing an internal procedural standard aimed at providing people with better conditions of safety through compliant behaviour. They are also intended to prevent unauthorised persons from accessing the area dedicated to processing with LASER equipment. In particular, a Standard Operating Procedure (SOP) is defined in relation to the manoeuvres to be carried out for commissioning and decommissioning the Equipment. This procedure must be illustrated near the installation, as a reference for the Operator and must be written in their language. Personnel training will nevertheless be essential, which must be aimed at:

- Familiarising with the operating procedures of the system;
- Appropriate use of the hazard control procedures, warning signs, etc.;
- Need for personal protection;
- Biological effects of the LASER on eyes and skin;

PERSONAL PROTECTION, PERSONAL PROTECTIVE EQUIPMENT (PPE)

These devices must be considered an additional safety measure to complement those protection systems indicated in A and B and not as the main or the only safety measure! They consist of the eyepiece protectors and it is clear that they must be of very safe and certified compliance, since they are the last barrier between the eye and the radiation! The OD of the eyewear must be calculated according to regulatory recommendations providing for the worst viewing conditions.

In any case it is good to remember that no eyewear can effectively protect the eye from the direct view of the LASER beam!

RESIDUAL RISKS THAT THE USER MUST IDENTIFY AND ELIMINATE

These are risks deriving not from the LASER itself but from its use. In fact, collateral radiations are associated with the main radiation, and consist of the visible infrared type, and ultraviolet, which due to their intensity, can represent potential danger.

Due to its high power density (irradiation), the LASER beam can trigger the combustion of flammable substances, such as volatile substances (solvents, gasolines, ethers, alcohols, etc.) as well as plastic or methacrylate resins.

The interaction of the LASER beam with organic and inorganic materials causes the formation of fumes and vapours which, in some cases, can be harmful to health and/or toxic!

Often, the lens is cleaned with a highly flammable and irritating solvent for the eyes and inhalation.

Warnings

The following warnings must be highlighted in order to minimise residual risks:

- Do not remove the lamp casings and the protective barriers.
- Use goggles and gloves when handling the lamps.
- When directing the LASER beam on materials considered to be flammable.
- Evacuate the fumes with a suitable extractor.
- Introduce the fumes into the environment only after filtration.
- Do not operate with live electrical equipment and with the protective barriers removed.
- Do not make adjustments while the Laser is running.
- Only expert and authorised personnel must be used.

Lastly, if all the requirements considered up to now have been fulfilled, it can be reasonably assumed that operating on a system that contains a LASER source does not involve higher risks than those of any other activity!

ELETTROLASER S.R.L.
Via Dell'Industria, 35
37060 SONA (VR)
TEL. +39 045 6082415 / FAX +39 0456088650
EMAIL info@elettrolaser.com
WWW.ELETTROLASER.COM